

ON DWG		REV	ZONE	DESCRIPTIONS	DRWN	APPVD

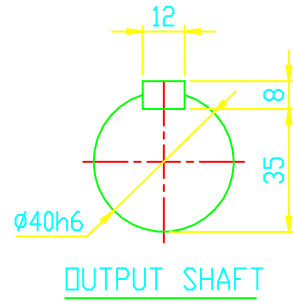

OUTPUT SHAFT

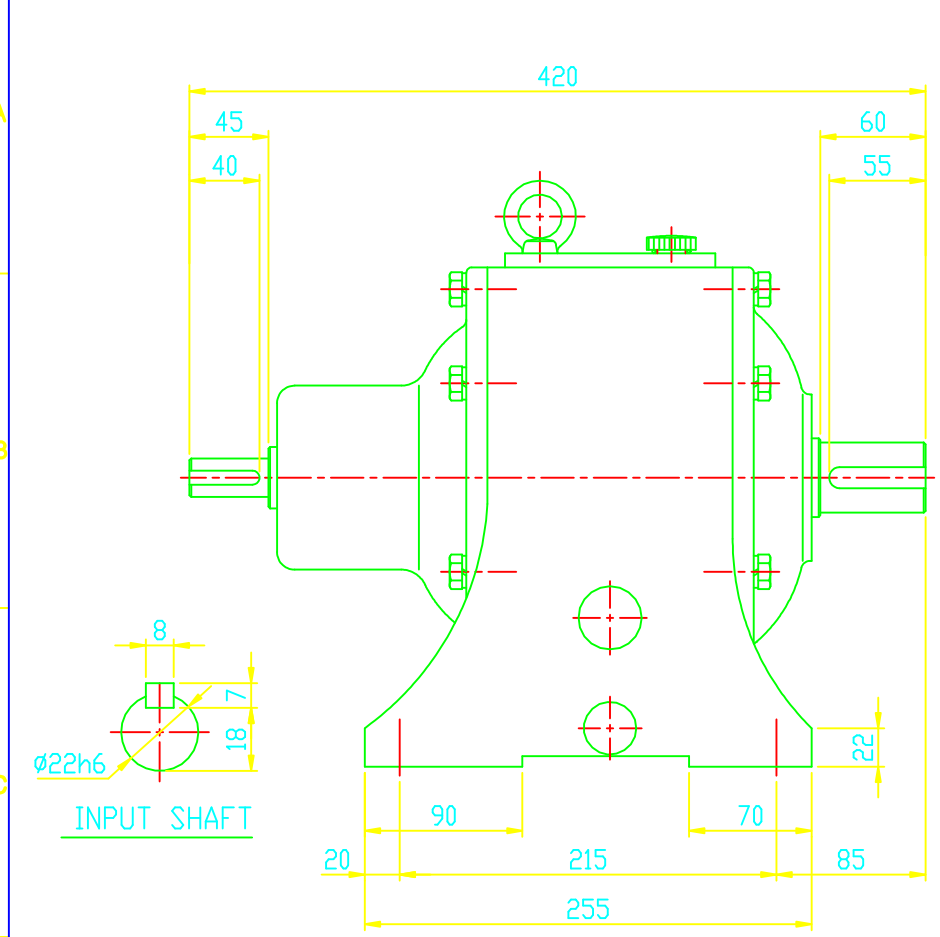
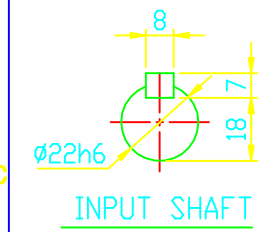
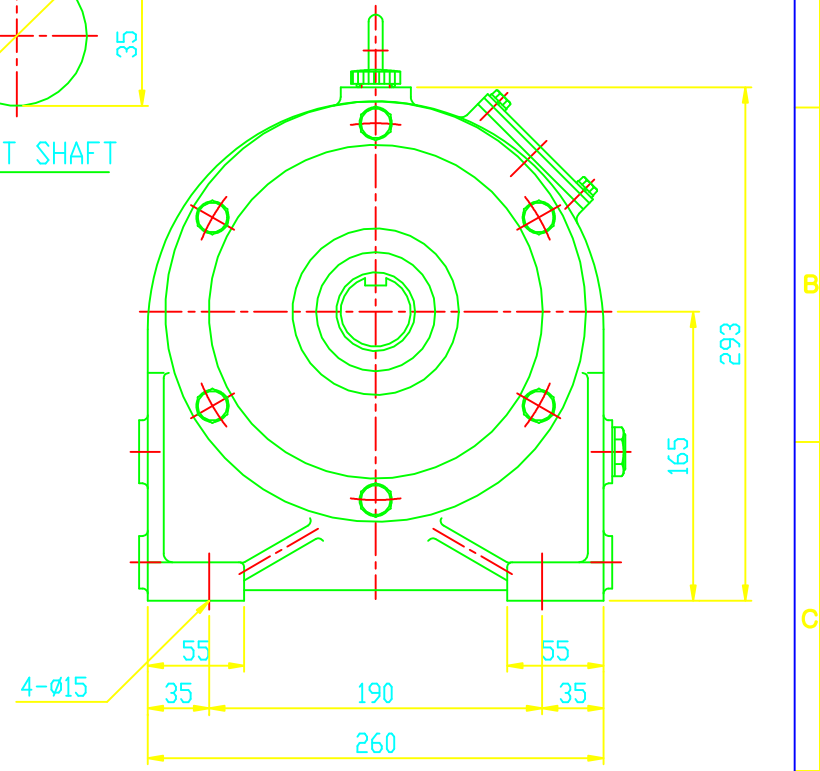

INPUT SHAFT

표기외 표준 가공 및 공차	표기외 표준 가공 및 공차
각도: ±0.5°	6 - 80 : ±0.1
CHAMFER: C1.0	30 - 120 : ±0.15
FILLET: R1.0	120 - 315 : ±0.2
마무리: ▽	315 - 1000 : ±0.3
열처리: HRC	1000 이상 : ±0.5

NO	PART NUMBER	DESCRIPTIONS	Q'TY	MATERIAL
		SY SUPER MAX-OUT LINE C80 SL 2 STAGE		
		1.5KW 4P i = 1/10 ~ 1/30		
		DWG SIZE A4	DWG. NO. SL2165-1K	REV



DESIGNED: 김영남 00.10.13
 CHECKED:
 APPROVED:
 DWG. NO. SL2165-1K

본 도면은 (주)삼양감속기의 기밀정보이며, 무단으로 복제, 배포, 전수 또는 외부에 유출하는 행위는 법적 책임을 질 수 있습니다.